

PRONOVA
PACKAGING SYSTEMS

JOKER

Packaging
the way you want it
- Flexible, cost-efficient
& convenient





A photograph of a large industrial building with a corrugated metal facade and brick accents. Two tall flagpoles stand in the foreground, each flying a white flag with the Pronova logo. The sky is blue with scattered white clouds. The building has several windows and a chimney stack on the roof.

Pronova AB

We develop, manufacture and sell the JOKER® packaging system consisting of packaging machines and bags.

From a wide range of standard machines and bags and in close cooperation with our customers, we offer qualified solutions to any company with a product that can be packed in a bag.

We can customize our machines and bags to suit your products and so that they meet the wishes and requirements you have in your production.



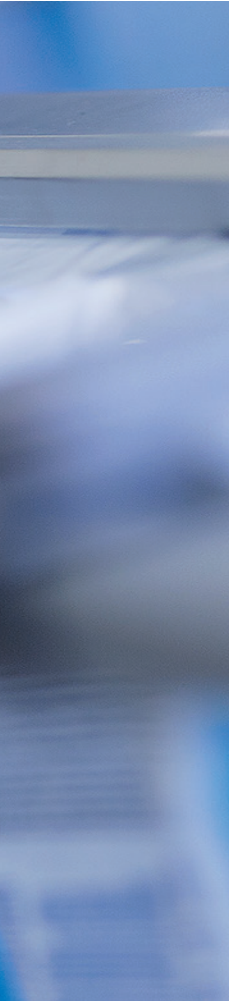

Joker® packaging system

In 1980, Pronova invented a unique packaging concept named Joker®.

Since then, we have manufactured packaging machines and linked bags according to this concept to anyone in need of a cost-efficient and automated packaging system for their products.



Packaging the way
you want it:

Flexible,
cost-efficient
& convenient.

Quality that pays off.





Pronova 505

Pronova 505 is our smallest machine model, with a simple and uncomplicated design.

It is particularly well suited for smaller, growing productions where the packaging process needs to go from manual packing to become a little more automated and a lot more efficient.

With or without work table.

Standard sealing speed: 7 m/minute

Power: 1,2 kW

Electrical supply: 230 V 1-phase

Compressed air: Not needed





Pronova 510

The Pronova 510 is a versatile and efficient machine that is suitable for packing a wide range of various products.

It is mainly designed for manual filling and for the somewhat simpler in-line productions.

With the optional work table it becomes a highly operator-friendly work station for efficient manual filling.

Standard sealing speed: 9 m/minute

Power: 1,2 kW

Electrical supply: 230 V 1-phase

Compressed air: 600kPa, 0,06 m³/h





Pronova 520

Pronova 520 bag packaging machine is a robust machine that automatically and without staples places cardboard headers onto the bag as they are being sealed.

The result is an attractive and practical pin-pack.

Can be used without the header application.

Max. sealing speed: 45 bags/minute

Power: 3 kW

Electrical supply: 400 V 3-phase

Compressed air: 600kPa, 7 m³/h





Pronova 525

The Pronova 525 is a powerful and efficient packaging machine designed mainly for heavy use in automatic filling lines.

The optional conveyor belt supports heavy products.

Max. sealing speed: 30 m/minute

Power: 2,5 kW

Electrical supply: 400 V 3-phase

Compressed air: 600kPa, 0,06 m³/h



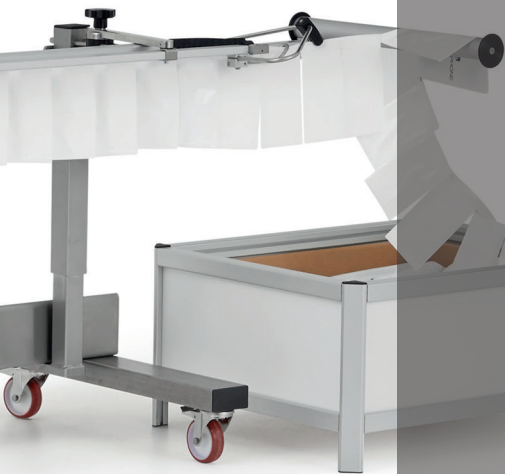

Pronova 535

The Pronova 535 is a stainless steel version of the 525 model. Designed for packaging of products that require hygienic handling and can be washed down. It is a powerful and efficient packaging machine for heavy use in automatic filling lines.

The optional conveyor belt supports heavy products.

Max. sealing speed: 30 m/minutes

Power: 2,5 kW

Electrical supply: 400 V 3-phase

Compressed air: 600kPa, 0,06 m³/h





Pronova 525H/535H

Pronova 525H and the stainless steel version 535H are powerful and efficient packaging machines for horizontal bag packaging.

They are designed for use in automatic filling lines where the products need extra careful handling.

The 535H is especially suitable for products that require hygienic packing as it can be washed down.

Max. sealing speed: 30 m/minute

Power: 2,5 kW

Electrical supply: 400 V 3-phase

Compressed air: 600kPa, 0,06 m³/h

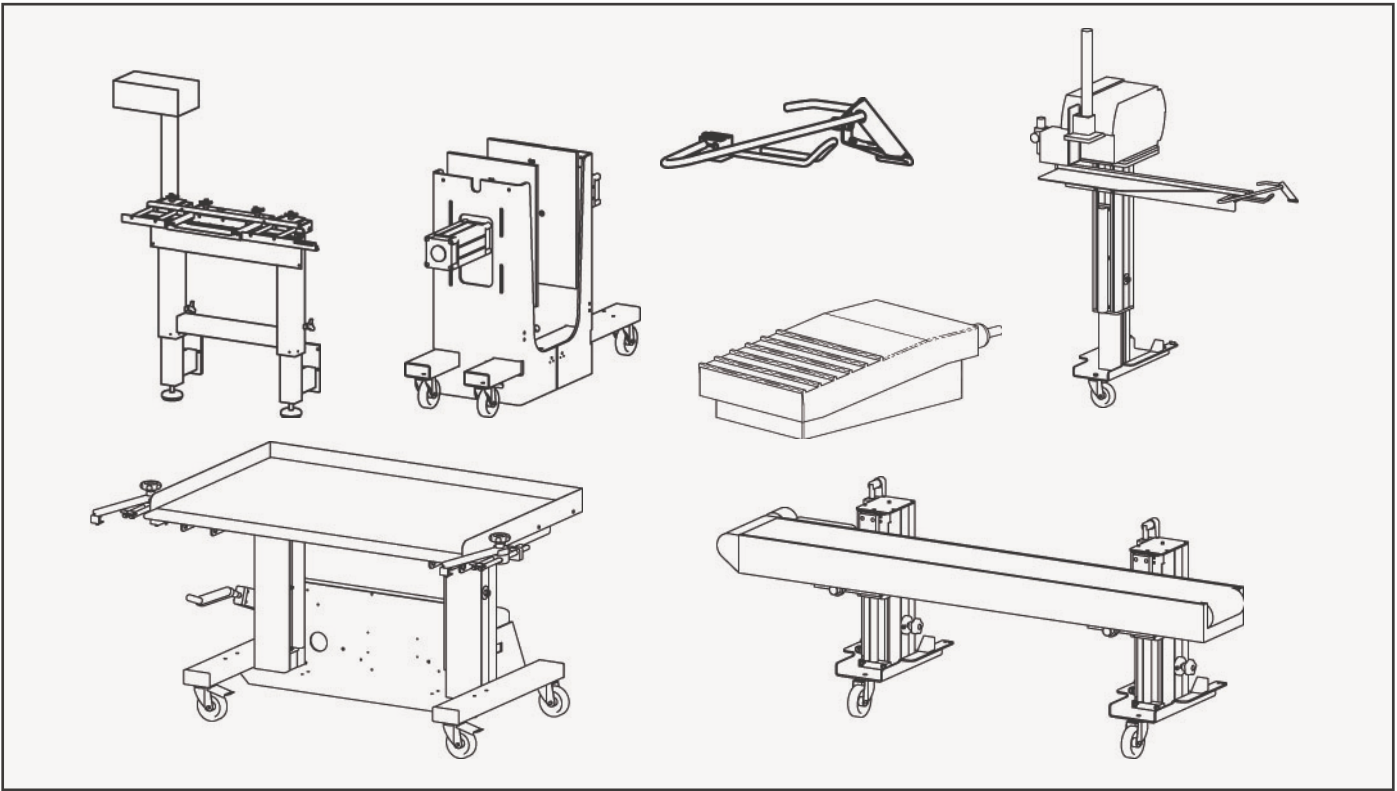

Optional equipment

Examples of our optional equipment that can complement the machines:

- Foot pedal
- Work table
- Supporting conveyor belt
- Print stand
- Label application
- Inkjet printing
- Thermal transfer printing
- MAP (modified atmosphere)
- Compressor unit
- Air evacuation unit
- Funnel
- Vibration unit
- Sensor no-bag

Customized solutions

The Pronova bag packaging system builds on flexibility, which enables us to offer our customers customized machine solutions based on each specific product and production.

The machines are prepared for integration with existing production equipment or external filling units to become a part of fully automated production lines.

Nr.	Pcs.	Art.Nr	Description	Remark
1	1	P1-29712	505 BAGGING MACHINE	
2	1	P2-28843	SESAMMÅN 310/435	X-LÅNGD
3	2	PS-29731	ARMHÅLLARE / HOLDER	505
4	1	PS-29732	ARMHÅLLARE / HÅLLARE	
5	1	PS-29733	ARMHÅLLARE / HÅLLARE	
6	1	PS-29734	ARMHÅLLARE / HÅLLARE	
7	1	PS-29735	ARMHÅLLARE / HÅLLARE	
8	1	PS-29736	ARMHÅLLARE / HÅLLARE	
9	1	PS-29737	ARMHÅLLARE / HÅLLARE	
10	1	PS-29738	ARMHÅLLARE / HÅLLARE	
11	1	PS-31120	FASTBRACKET	505 MOBIL
12	1	PS-31121	FASTBRACKET	BAG CHAIN SUPPORT APPL.
13	1	PS-31122	FASTBRACKET	
14	1	PS-31123	FASTBRACKET	
15	1	PS-31124	FASTBRACKET	
16	1	PS-31125	FASTBRACKET	
17	1	PS-31126	FASTBRACKET	
18	1	PS-31127	FASTBRACKET	
19	1	PS-31128	FASTBRACKET	
20	1	PS-31129	FASTBRACKET	
21	1	PS-31130	FASTBRACKET	BEACON
22	1	PS-31131	FASTBRACKET	
23	1	PS-31132	FASTBRACKET	
24	1	PS-31133	FASTBRACKET	
25	1	PS-31134	FASTBRACKET	
26	1	PS-31135	FASTBRACKET	
27	1	PS-31136	FASTBRACKET	
28	1	PS-31137	FASTBRACKET	
29	1	PS-31138	FASTBRACKET	
30	1	PS-31139	FASTBRACKET	
31	1	PS-31140	FASTBRACKET	
32	1	PS-31141	FASTBRACKET	
33	1	PS-31142	FASTBRACKET	
34	1	PS-31143	FASTBRACKET	
35	1	PS-31144	FASTBRACKET	
36	1	PS-31145	FASTBRACKET	
37	1	PS-31146	FASTBRACKET	
38	1	PS-31147	FASTBRACKET	
39	1	PS-31148	FASTBRACKET	
40	1	PS-31149	FASTBRACKET	
41	1	PS-31150	FASTBRACKET	
42	1	PS-31151	FASTBRACKET	
43	1	PS-31152	FASTBRACKET	
44	1	PS-31153	FASTBRACKET	
45	1	PS-31154	FASTBRACKET	
46	1	PS-31155	FASTBRACKET	
47	1	PS-31156	FASTBRACKET	
48	1	PS-31157	FASTBRACKET	
49	1	PS-31158	FASTBRACKET	
50	1	PS-31159	FASTBRACKET	
51	1	PS-31160	FASTBRACKET	
52	1	PS-31161	FASTBRACKET	
53	1	PS-31162	FASTBRACKET	
54	1	PS-31163	FASTBRACKET	
55	1	PS-31164	FASTBRACKET	
56	1	PS-31165	FASTBRACKET	
57	1	PS-31166	FASTBRACKET	
58	1	PS-31167	FASTBRACKET	
59	1	PS-31168	FASTBRACKET	
60	1	PS-31169	FASTBRACKET	
61	1	PS-31170	FASTBRACKET	
62	1	PS-31171	FASTBRACKET	
63	1	PS-31172	FASTBRACKET	
64	1	PS-31173	FASTBRACKET	
65	1	PS-31174	FASTBRACKET	
66	1	PS-31175	FASTBRACKET	
67	1	PS-31176	FASTBRACKET	
68	1	PS-31177	FASTBRACKET	
69	1	PS-31178	FASTBRACKET	
70	1	PS-31179	FASTBRACKET	
71	1	PS-31180	FASTBRACKET	
72	1	PS-31181	FASTBRACKET	
73	1	PS-31182	FASTBRACKET	
74	1	PS-31183	FASTBRACKET	
75	1	PS-31184	FASTBRACKET	
76	1	PS-31185	FASTBRACKET	
77	1	PS-31186	FASTBRACKET	
78	1	PS-31187	FASTBRACKET	
79	1	PS-31188	FASTBRACKET	
80	1	PS-31189	FASTBRACKET	
81	1	PS-31190	FASTBRACKET	
82	1	PS-31191	FASTBRACKET	
83	1	PS-31192	FASTBRACKET	
84	1	PS-31193	FASTBRACKET	
85	1	PS-31194	FASTBRACKET	
86	1	PS-31195	FASTBRACKET	
87	1	PS-31196	FASTBRACKET	
88	1	PS-31197	FASTBRACKET	
89	1	PS-31198	FASTBRACKET	
90	1	PS-31199	FASTBRACKET	
91	1	PS-31200	FASTBRACKET	
92	1	PS-31201	FASTBRACKET	
93	1	PS-31202	FASTBRACKET	
94	1	PS-31203	FASTBRACKET	
95	1	PS-31204	FASTBRACKET	
96	1	PS-31205	FASTBRACKET	
97	1	PS-31206	FASTBRACKET	
98	1	PS-31207	FASTBRACKET	
99	1	PS-31208	FASTBRACKET	
100	1	PS-31209	FASTBRACKET	
101	1	PS-31210	FASTBRACKET	
102	1	PS-31211	FASTBRACKET	
103	1	PS-31212	FASTBRACKET	
104	1	PS-31213	FASTBRACKET	
105	1	PS-31214	FASTBRACKET	
106	1	PS-31215	FASTBRACKET	
107	1	PS-31216	FASTBRACKET	
108	1	PS-31217	FASTBRACKET	
109	1	PS-31218	FASTBRACKET	
110	1	PS-31219	FASTBRACKET	
111	1	PS-31220	FASTBRACKET	
112	1	PS-31221	FASTBRACKET	
113	1	PS-31222	FASTBRACKET	
114	1	PS-31223	FASTBRACKET	
115	1	PS-31224	FASTBRACKET	
116	1	PS-31225	FASTBRACKET	
117	1	PS-31226	FASTBRACKET	
118	1	PS-31227	FASTBRACKET	
119	1	PS-31228	FASTBRACKET	
120	1	PS-31229	FASTBRACKET	
121	1	PS-31230	FASTBRACKET	
122	1	PS-31231	FASTBRACKET	
123	1	PS-31232	FASTBRACKET	
124	1	PS-31233	FASTBRACKET	
125	1	PS-31234	FASTBRACKET	
126	1	PS-31235	FASTBRACKET	
127	1	PS-31236	FASTBRACKET	
128	1	PS-31237	FASTBRACKET	
129	1	PS-31238	FASTBRACKET	
130	1	PS-31239	FASTBRACKET	
131	1	PS-31240	FASTBRACKET	
132	1	PS-31241	FASTBRACKET	
133	1	PS-31242	FASTBRACKET	
134	1	PS-31243	FASTBRACKET	
135	1	PS-31244	FASTBRACKET	
136	1	PS-31245	FASTBRACKET	
137	1	PS-31246	FASTBRACKET	
138	1	PS-31247	FASTBRACKET	
139	1	PS-31248	FASTBRACKET	
140	1	PS-31249	FASTBRACKET	
141	1	PS-31250	FASTBRACKET	
142	1	PS-31251	FASTBRACKET	
143	1	PS-31252	FASTBRACKET	
144	1	PS-31253	FASTBRACKET	
145	1	PS-31254	FASTBRACKET	
146	1	PS-31255	FASTBRACKET	
147	1	PS-31256	FASTBRACKET	
148	1	PS-31257	FASTBRACKET	
149	1	PS-31258	FASTBRACKET	
150	1	PS-31259	FASTBRACKET	
151	1	PS-31260	FASTBRACKET	
152	1	PS-31261	FASTBRACKET	
153	1	PS-31262	FASTBRACKET	
154	1	PS-31263	FASTBRACKET	
155	1	PS-31264	FASTBRACKET	
156	1	PS-31265	FASTBRACKET	
157	1	PS-31266	FASTBRACKET	
158	1	PS-31267	FASTBRACKET	
159	1	PS-31268	FASTBRACKET	
160	1	PS-31269	FASTBRACKET	
161	1	PS-31270	FASTBRACKET	
162	1	PS-31271	FASTBRACKET	
163	1	PS-31272	FASTBRACKET	
164	1	PS-31273	FASTBRACKET	
165	1	PS-31274	FASTBRACKET	
166	1	PS-31275	FASTBRACKET	
167	1	PS-31276	FASTBRACKET	
168	1	PS-31277	FASTBRACKET	
169	1	PS-31278	FASTBRACKET	
170	1	PS-31279	FASTBRACKET	
171	1	PS-31280	FASTBRACKET	
172	1	PS-31281	FASTBRACKET	
173	1	PS-31282	FASTBRACKET	
174	1	PS-31283	FASTBRACKET	
175	1	PS-31284	FASTBRACKET	
176	1	PS-31285	FASTBRACKET	
177	1	PS-31286	FASTBRACKET	
178	1	PS-31287	FASTBRACKET	
179	1	PS-31288	FASTBRACKET	
180	1	PS-31289	FASTBRACKET	
181	1	PS-31290	FASTBRACKET	
182	1	PS-31291	FASTBRACKET	
183	1	PS-31292	FASTBRACKET	
184	1	PS-31293	FASTBRACKET	
185	1	PS-31294	FASTBRACKET	
186	1	PS-31295	FASTBRACKET	
187	1	PS-31296	FASTBRACKET	
188	1	PS-31297	FASTBRACKET	
189	1	PS-31298	FASTBRACKET	
190	1	PS-31299	FASTBRACKET	
191	1	PS-31300	FASTBRACKET	
192	1	PS-31301	FASTBRACKET	
193	1	PS-31302	FASTBRACKET	
194	1	PS-31303	FASTBRACKET	
195	1	PS-31304	FASTBRACKET	
196	1	PS-31305	FASTBRACKET	
197	1	PS-31306	FASTBRACKET	
198	1	PS-31307	FASTBRACKET	
199	1	PS-31308	FASTBRACKET	
200	1	PS-31309	FASTBRACKET	
201	1	PS-31310	FASTBRACKET	
202	1	PS-31311	FASTBRACKET	
203	1	PS-31312	FASTBRACKET	
204	1	PS-31313	FASTBRACKET	
205	1	PS-31314	FASTBRACKET	
206	1	PS-31315	FASTBRACKET	
207	1	PS-31316	FASTBRACKET	
208	1	PS-31317	FASTBRACKET	
209	1	PS-31318	FASTBRACKET	
210	1	PS-31319	FASTBRACKET	
211	1	PS-31320	FASTBRACKET	
212	1	PS-31321	FASTBRACKET	
213	1	PS-31322	FASTBRACKET	
214	1	PS-31323	FASTBRACKET	
215	1	PS-31324	FASTBRACKET	
216	1	PS-31325	FASTBRACKET	
217	1	PS-31326	FASTBRACKET	
218	1	PS-31327	FASTBRACKET	
219	1	PS-31328	FASTBRACKET	
220	1	PS-31329	FASTBRACKET	
221	1	PS-31330	FASTBRACKET	
222	1	PS-31331	FASTBRACKET	
223	1	PS-31332	FASTBRACKET	
224	1	PS-31333	FASTBRACKET	
225	1	PS-31334	FASTBRACKET	
226	1	PS-31335	FASTBRACKET	
227	1	PS-31336	FASTBRACKET	
228	1	PS-31337	FASTBRACKET	
229	1	PS-31338	FASTBRACKET	
230	1	PS-31339	FASTBRACKET	
231	1	PS-31340	FASTBRACKET	
232	1	PS-31341	FASTBRACKET	
233	1	PS-31342	FASTBRACKET	
234	1	PS-31343	FASTBRACKET	
235	1	PS-31344	FASTBRACKET	
236	1	PS-31345	FASTBRACKET	
237	1	PS-31346	FASTBRACKET	
238	1	PS-31347	FASTBRACKET	
239	1	PS-31348	FASTBRACKET	
240	1	PS-31349	FASTBRACKET	
241	1	PS-31350	FASTBRACKET	
242	1	PS-31351	FASTBRACKET	
243	1	PS-31352	FASTBRACKET	
244	1	PS-31353	FASTBRACKET	
245	1	PS-31354	FASTBRACKET	
246	1	PS-31355	FASTBRACKET	
247	1	PS-31356	FASTBRACKET	
248	1	PS-31357	FASTBRACKET	
249	1	PS-31358	FASTBRACKET	
250	1	PS-31359	FASTBRACKET	
251	1	PS-31360	FASTBRACKET	
252	1	PS-31361	FASTBRACKET	
253	1	PS-31362	FASTBRACKET	
254	1	PS-31363	FASTBRACKET	
255	1	PS-31364	FASTBRACKET	
256	1	PS-31365	FASTBRACKET	
257	1	PS-31366	FASTBRACKET	
258	1	PS-31367	FASTBRACKET	
259	1	PS-31368	FASTBRACKET	
260	1	PS-31369	FASTBRACKET	
261	1	PS-31370	FASTBRACKET	
262	1	PS-31371	FASTBRACKET	
263	1	PS-31372	FASTBRACKET	
264	1	PS-31373	FASTBRACKET	
265	1	PS-31374	FASTBRACKET	
266	1	PS-31375	FASTBRACKET	
267	1	PS-31376	FASTBRACKET	
268	1	PS-31377	FASTBRACKET	
269	1	PS-31378	FASTBRACKET	
270	1	PS-31379	FASTBRACKET	
271	1	PS-31380	FASTBRACKET	
272	1	PS-31381	FASTBRACKET	
273	1	PS-31382	FASTBRACKET	
274	1	PS-31383	FASTBRACKET	
275	1	PS-31384	FASTBRACKET	
276	1	PS-31385	FASTBRACKET	
277	1	PS-31386	FASTBRACKET	
278	1	PS-31387	FASTBRACKET	
279	1	PS-31388	FASTBRACKET	
280	1	PS-31389	FASTBRACKET	
281	1	PS-31390	FASTBRACKET	
282	1	PS-31391	FASTBRACKET	
283	1	PS-31392	FASTBRACKET	
284	1	PS-31393	FASTBRACKET	
285	1	PS-31394	FASTBRACKET	
286	1	PS-31395	FASTBRACKET	
287	1	PS-31396	FASTBRACKET	
288	1	PS-31397	FASTBRACKET	
289	1	PS-31398	FASTBRACKET	
290	1	PS-31399	FASTBR	





Bags

Pronova's linked bags Joker® Line och Joker® Classic are bags that are uniquely designed for Pronova's packaging machines.

Materials: PE, laminates, PIR, PCR, paper 95/5

Sizes: 50 - 800 mm wide

Thickness 30 - 120 µm

Print: Flexography, up to 8 colours.

Optional features: zipper, perforation, air holes, stand-up, carrier handles, hanger holes, longitudinal seal, headers and more.



Printed material on roll

Material: All plastic materials

Printing method: Flexography

Number of colours: 8

thickness: 30 - 120 μm

Maximum print width: 1270 mm

Maximum roll width: 1320 mm

Outer diameter on roll: up to 1000 mm



Pronova AB
Olofsdalsvägen 26
302 41 Halmstad
Sweden

Call us: +46 35 171900
E-mail us: sales@pronovaab.se
www.pronovasweden.eu

	CERTIFIED ISO 9001 Quality management systems	
--	---	--

	CERTIFIED ISO 22000 Food safety management systems	
---	---	---

